

**HEAVY DUTY BICYCLE SAFE GRATE**

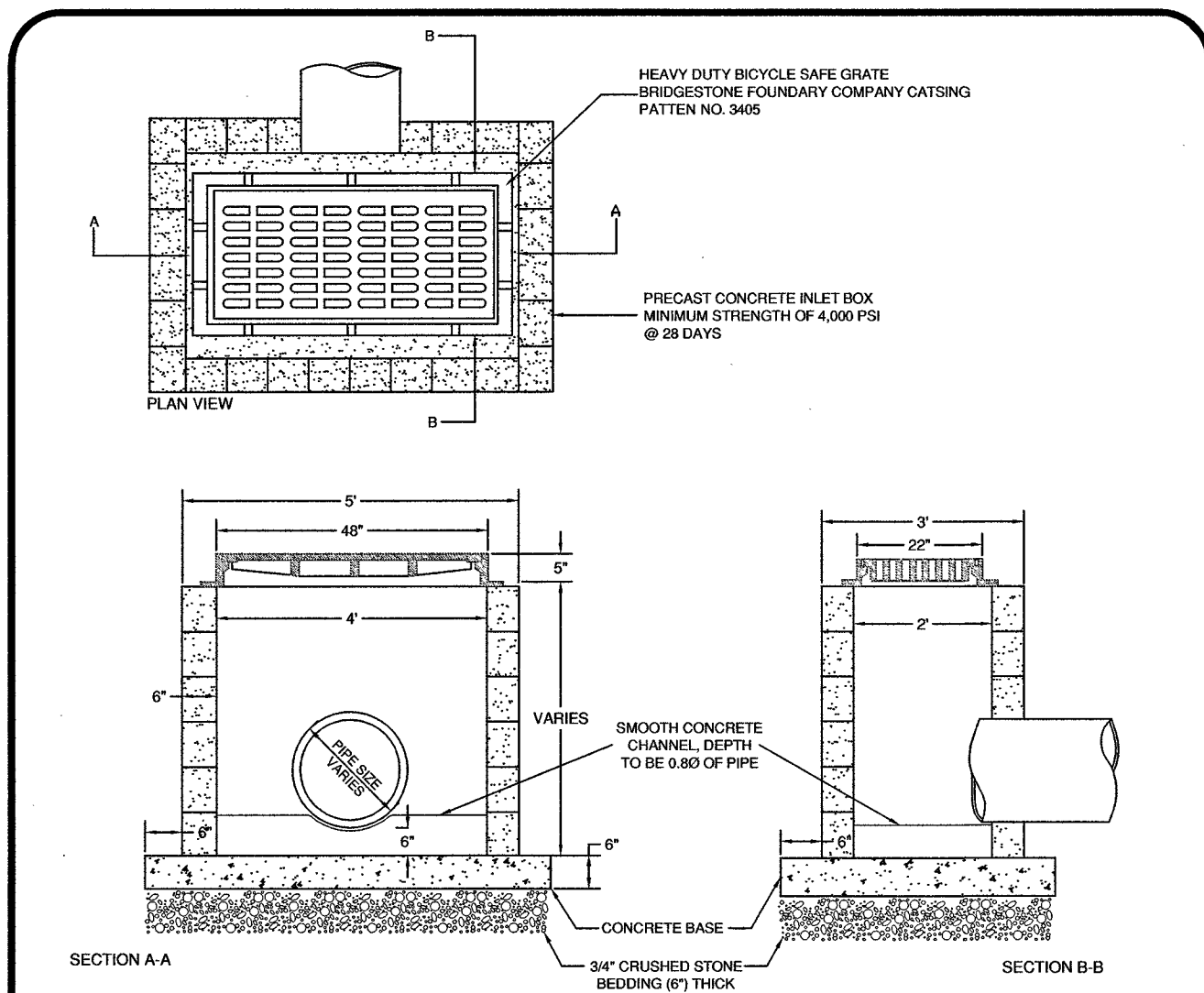

**TYPE A INLET DETAIL** N.T.S.

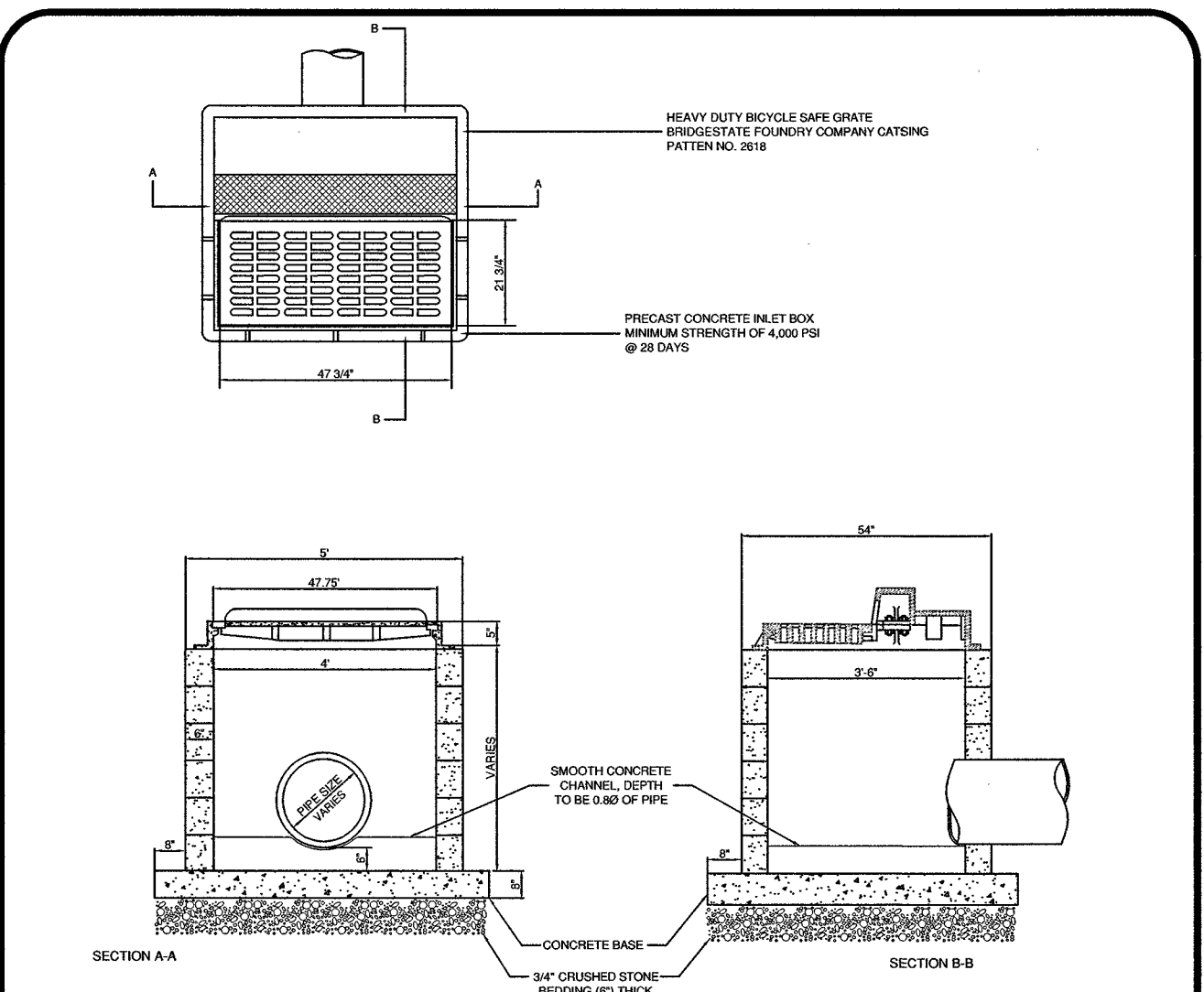

**TYPE B INLET DETAIL** N.T.S.

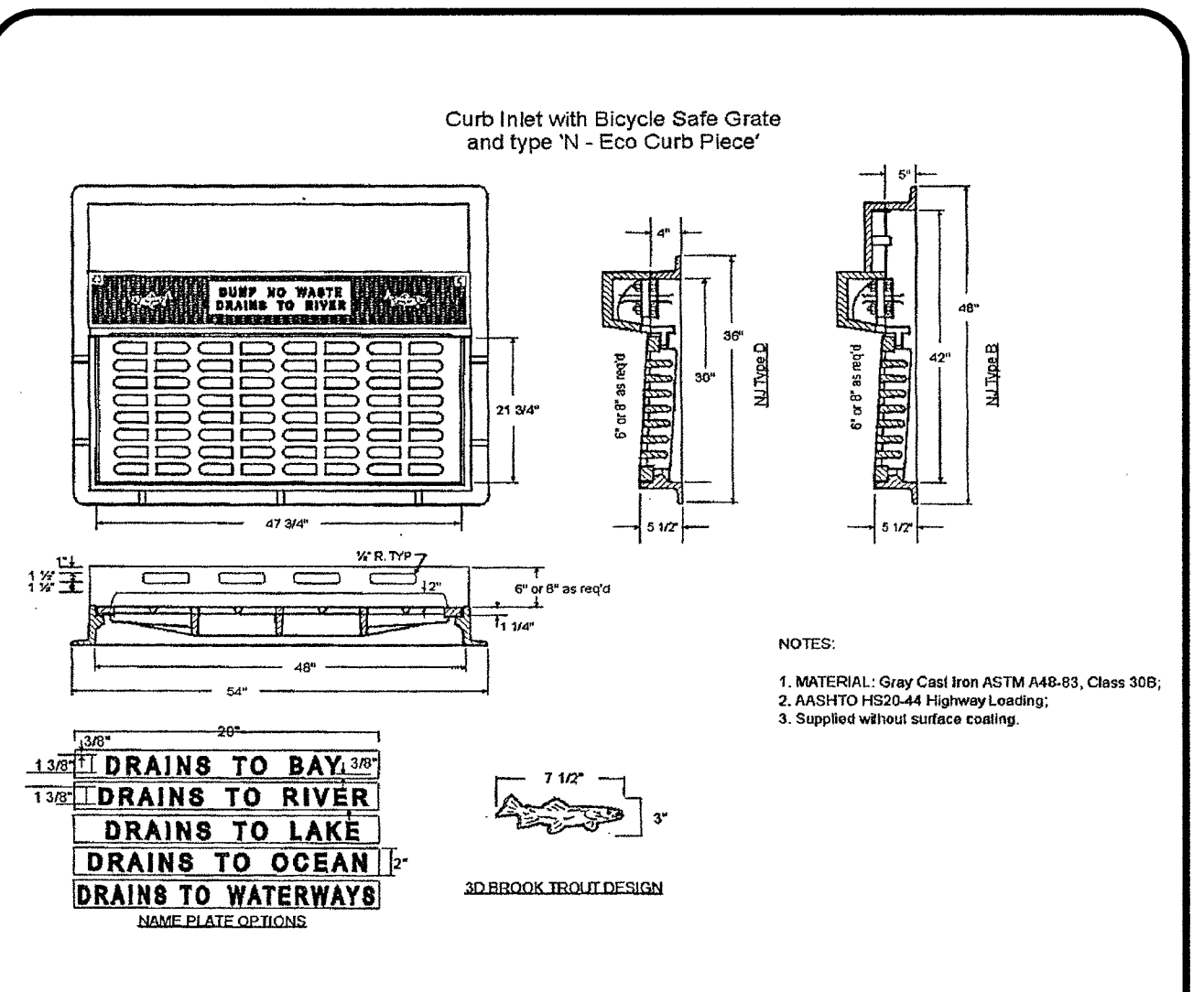

**HEAVY DUTY BICYCLE SAFE GRATE** N.T.S.

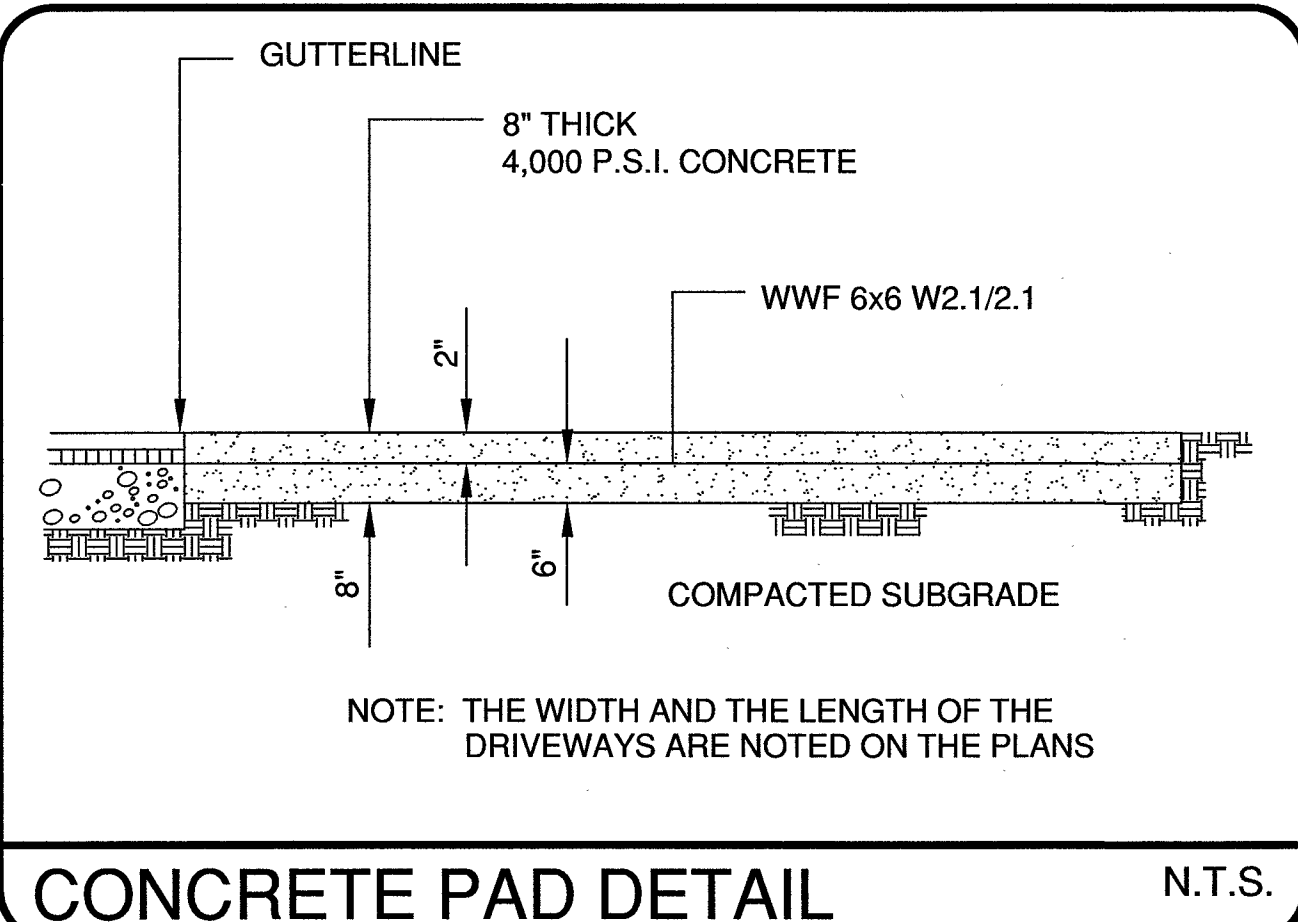

**CONCRETE PAD DETAIL** N.T.S.

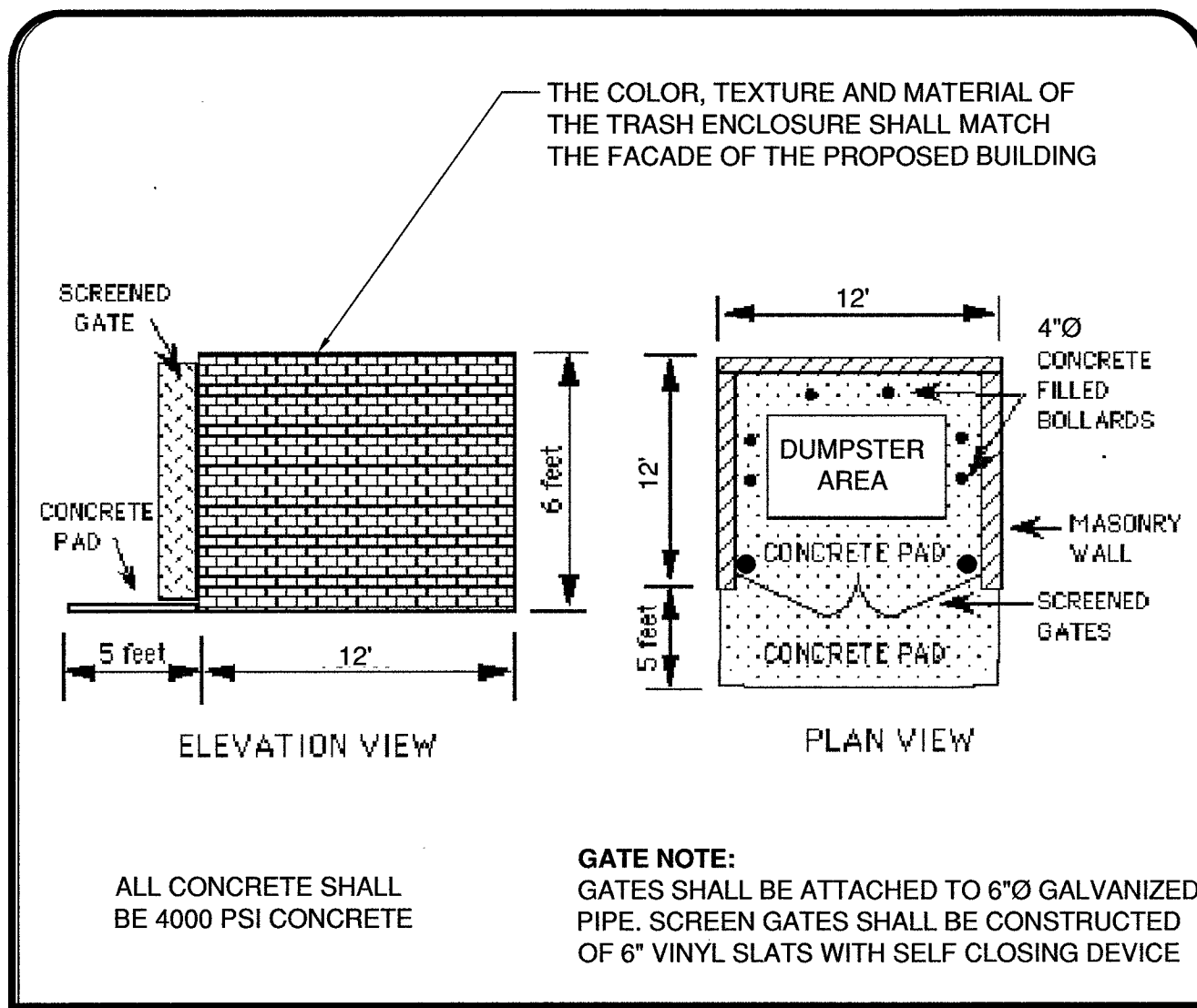

**MASONRY TRASH ENCLOSURE DETAIL** N.T.S.

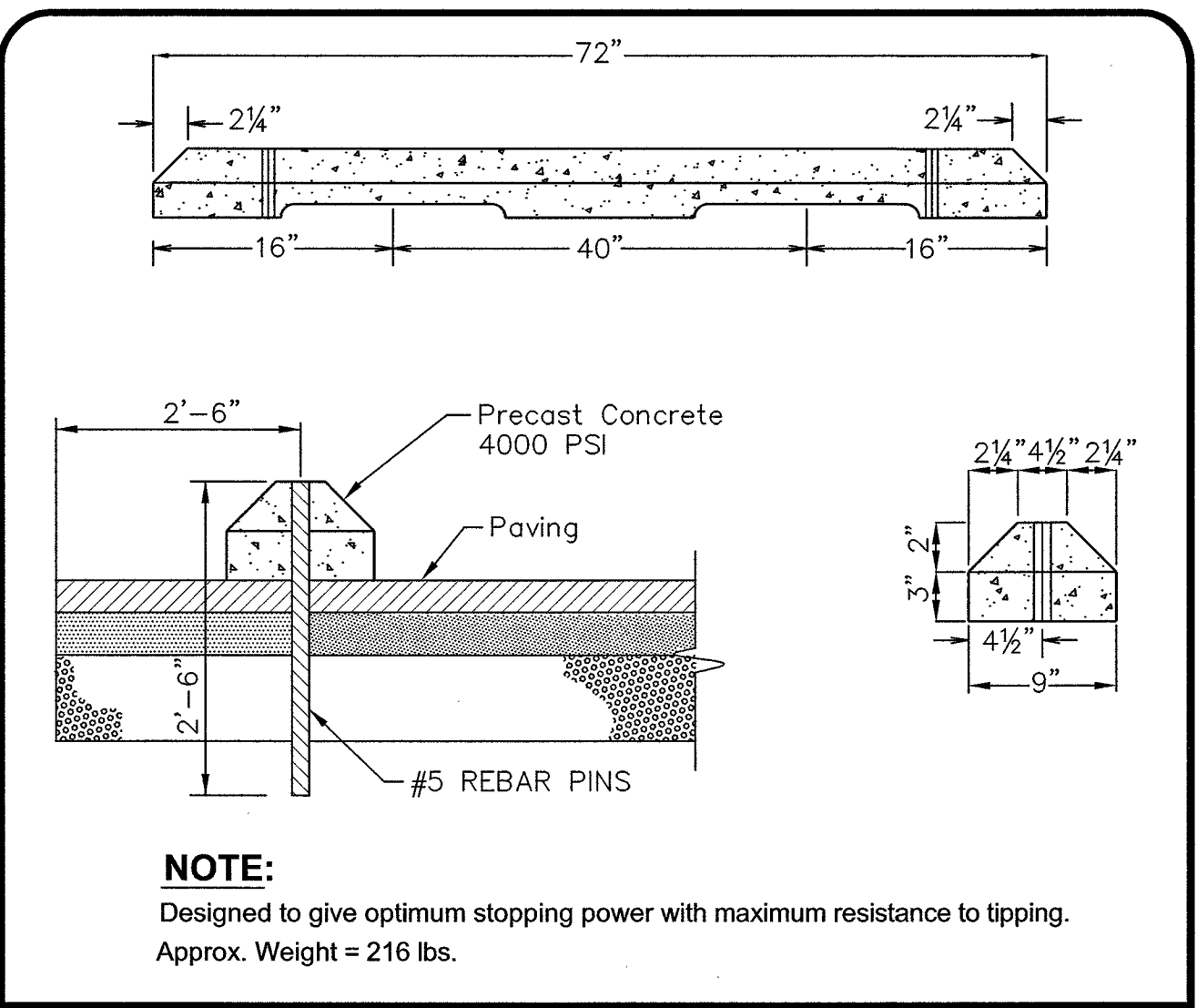

**WHEEL STOP DETAIL** N.T.S.

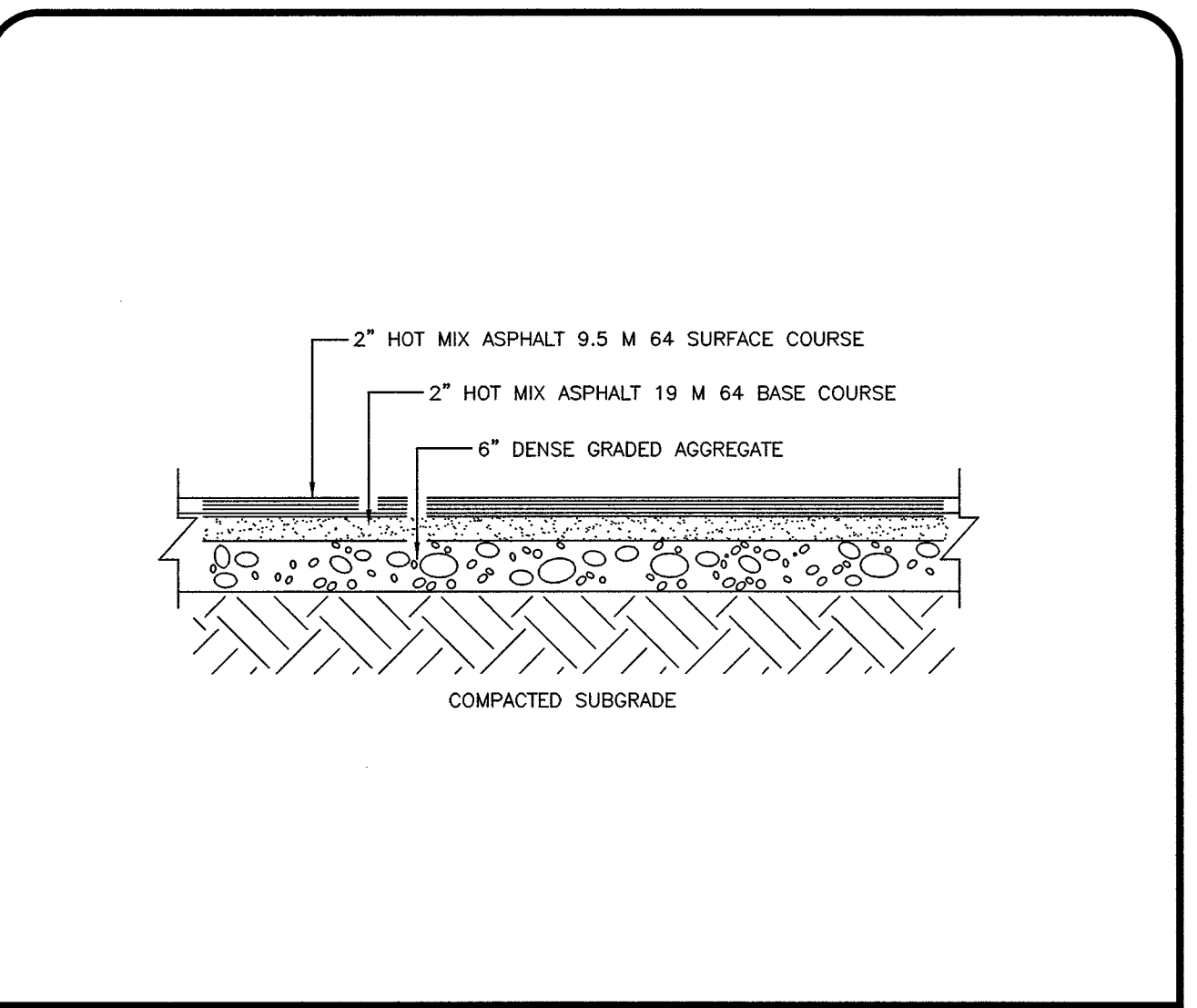

**ASPHALT PAVEMENT DETAIL** N.T.S.

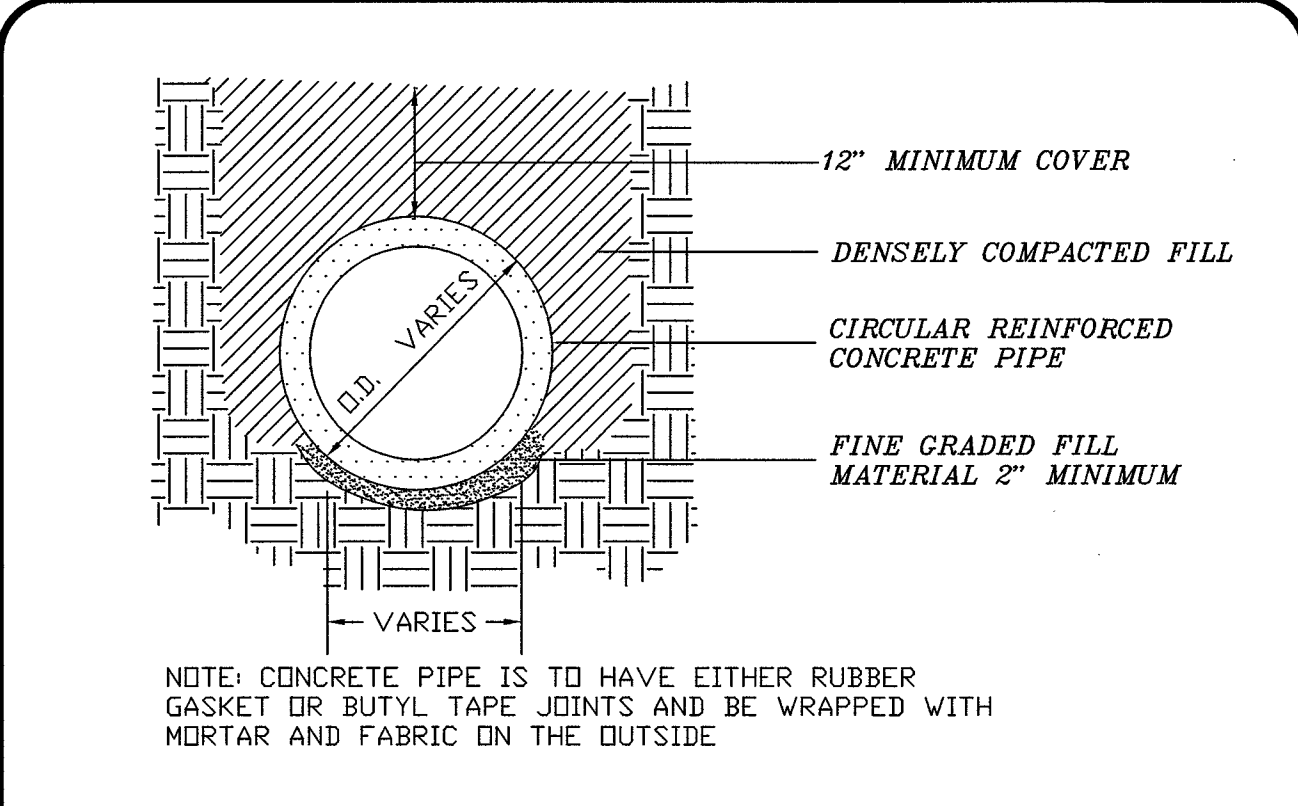

**PIPE BEDDING DETAIL** N.T.S.

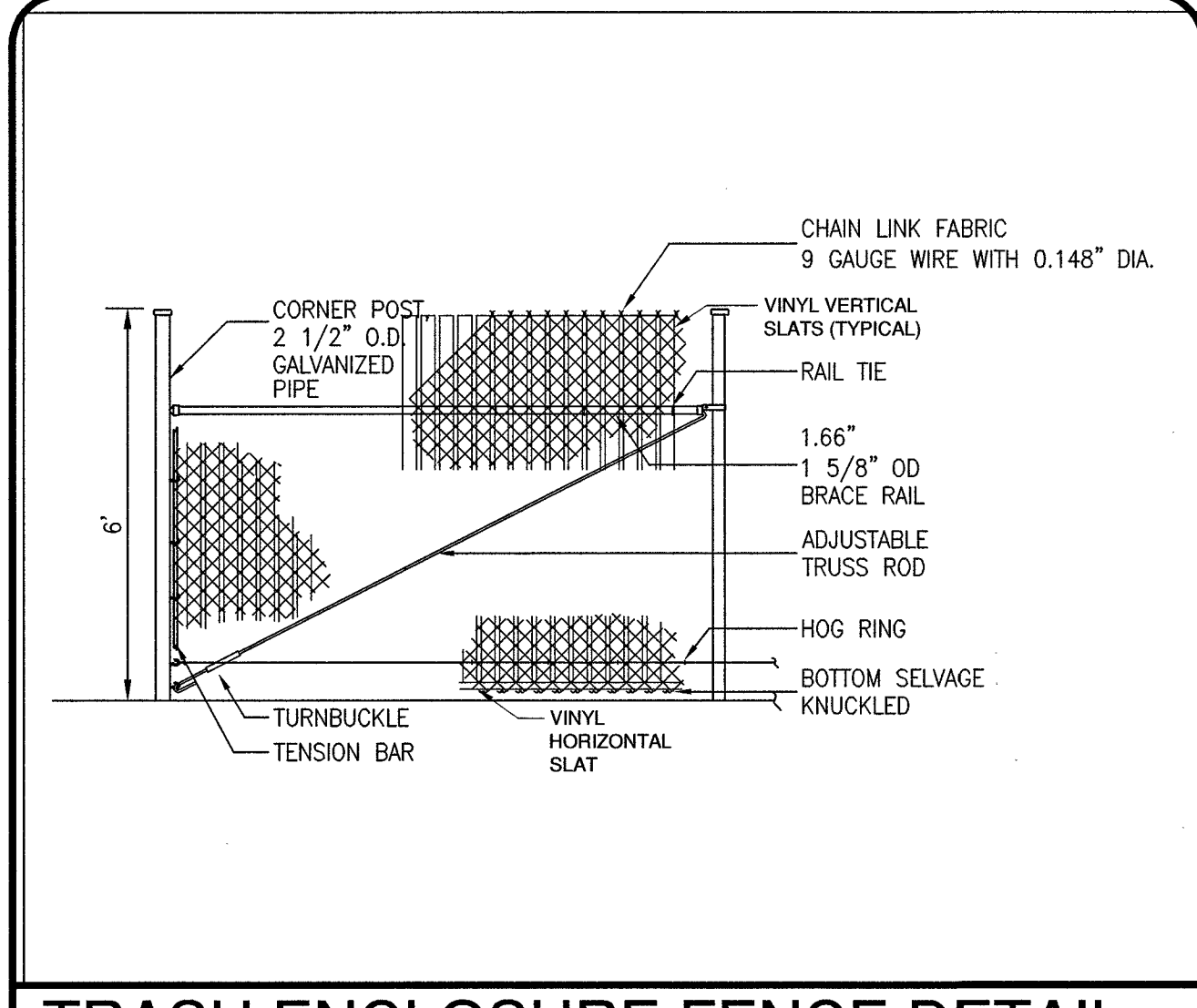

**TRASH ENCLOSURE FENCE DETAIL** N.T.S.

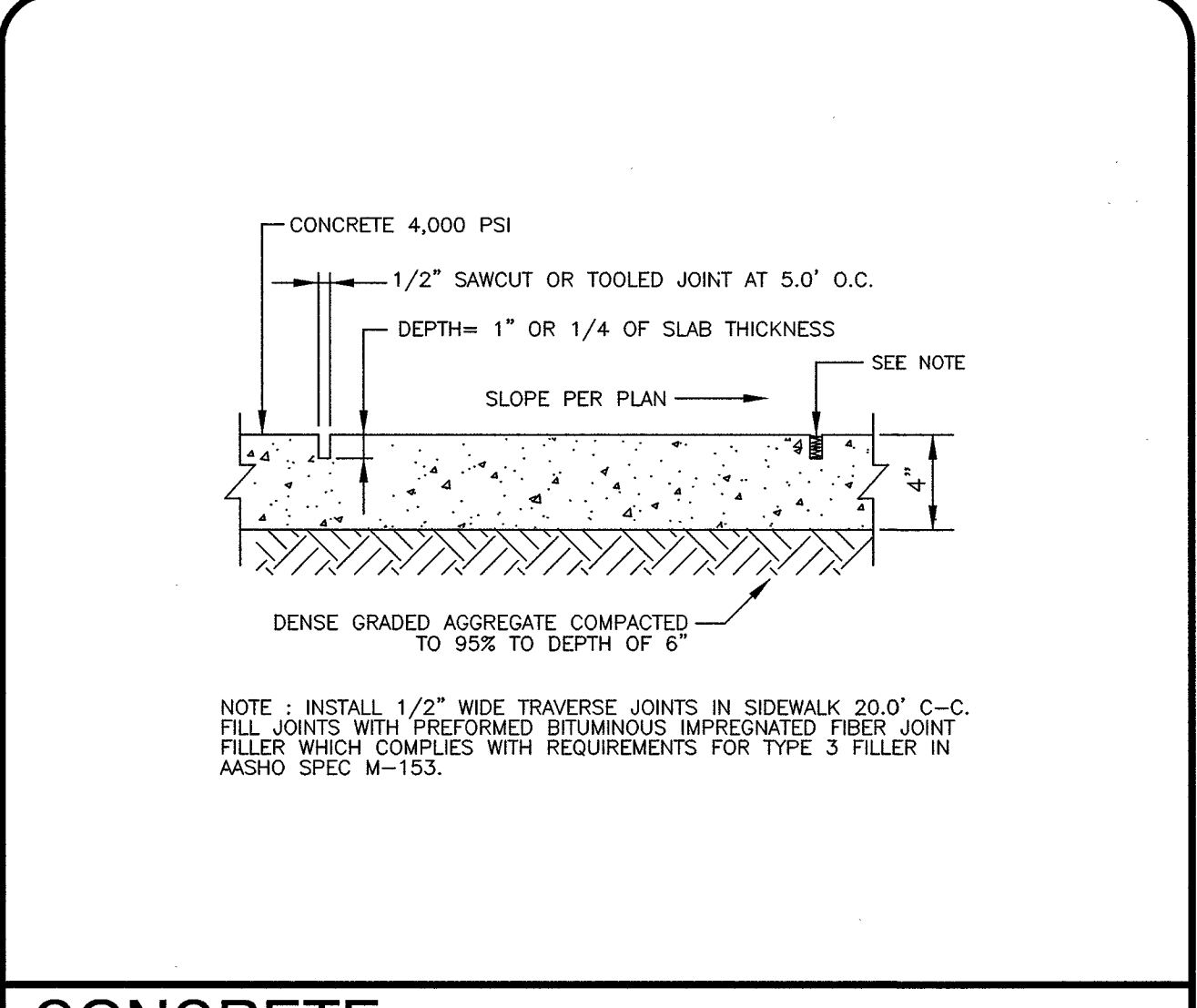

**CONCRETE SIDEWALK DETAIL** N.T.S.

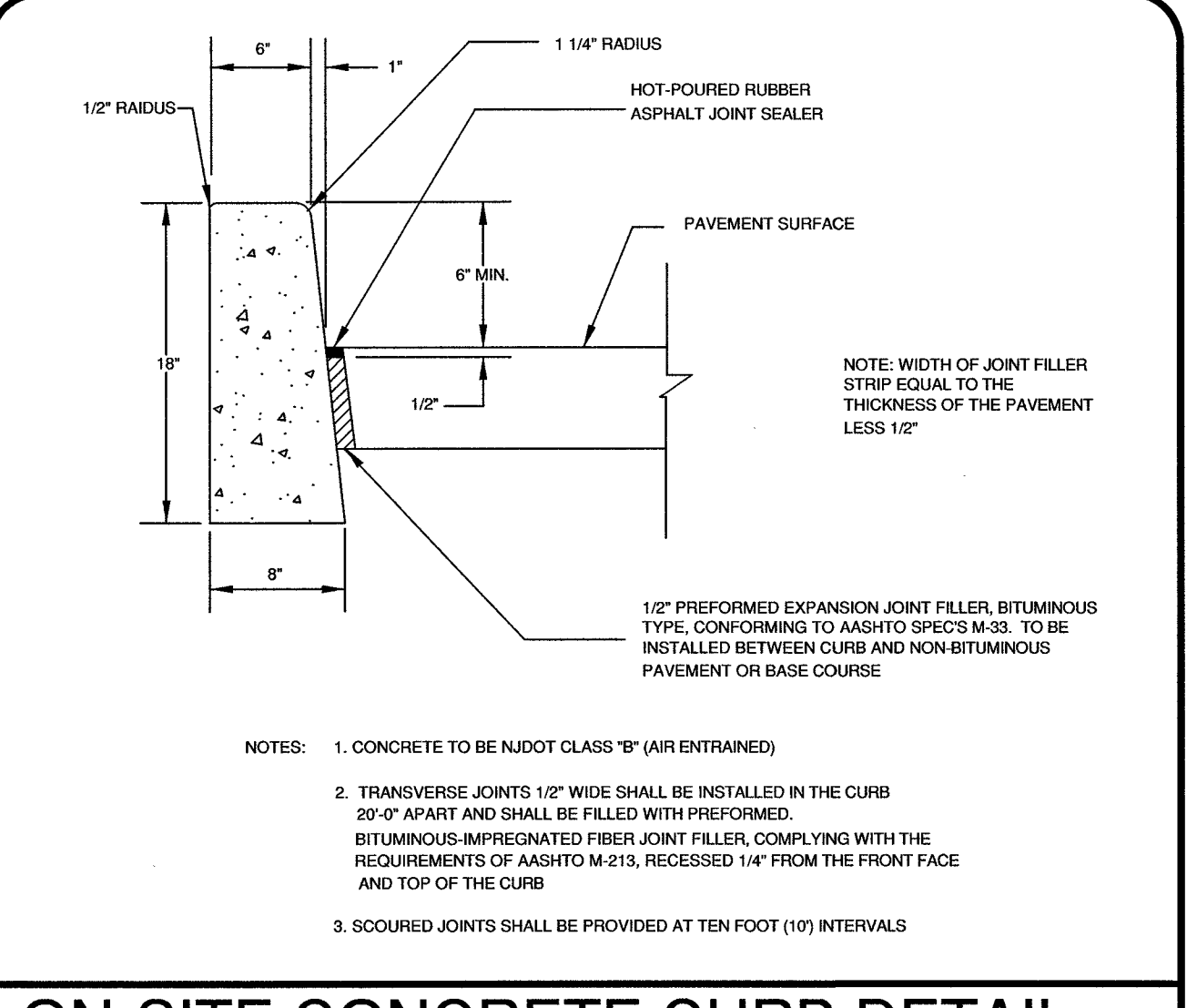

**ON-SITE CONCRETE CURB DETAIL** N.T.S.

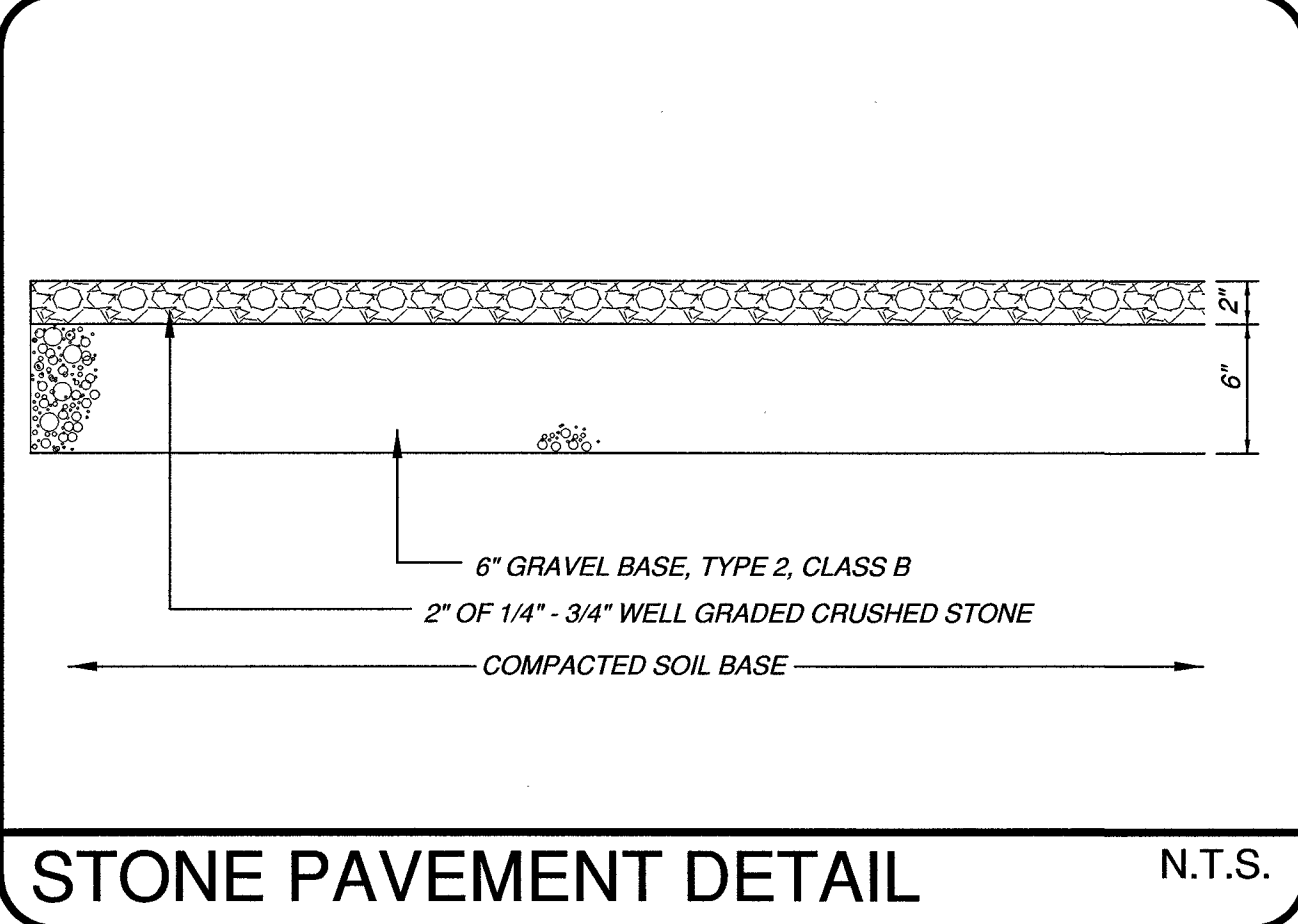

**STONE PAVEMENT DETAIL** N.T.S.

**EDA** Engineering Design Associates, P.A.  
 ENGINEERS, ENVIRONMENTAL PLANNERS, LANDSCAPE ARCHITECTS  
 CAMBRIDGE PROFESSIONAL OFFICES  
 5 Cambridge Drive Ocean View, New Jersey 08220  
 (609) 390-0332 • Fax (609) 390-9204  
 CERTIFICATE OF AUTHORIZATION: 2652797090

**ENGINEERING DETAILS 1**  
 BLOCK 6701, LOT 3  
 TOWNSHIP OF FRANKLIN  
 GLOUCESTER COUNTY, NEW JERSEY

**JOSEPH H. MAFFEI**  
 PROFESSIONAL ENGINEER  
 N.J.P.E. LIC. #37984

IF THIS PLAN OR DOCUMENT DOES NOT CONTAIN A RAISED SEAL IMPRESSION BEARING THE NAME AND REGISTRATION NUMBER OF THE ABOVE SIGNED PROFESSIONAL, IT MAY NOT BE AN AUTHORIZED COPY OF THE ORIGINAL DOCUMENT AND MAY HAVE BEEN ALTERED. REPRODUCTION OR FURTHER DISSEMINATION OF THE CONTENTS IN WHOLE OR IN PART REQUIRES PERMISSION IN WRITING FROM ENGINEERING DESIGN ASSOCIATES, P.A.

REV. PER ZONING BRD	12-16-14	JLB
REV. PER PINELANDS	5-19-14	JLB
REVISION	DATE	BY



DATE: 3/14/14	DRAWN BY: JLB
SCALE: AS NOTED	CHECKED BY: JHM
PROJECT #: 6745	SHEET: 6 OF 9