

CURB SIZE	DIM. A	DIM. B	DIM. C	DIM. D
9" x 16"	16"	4"	14"	2"
9" x 18"	18"	6"	16"	4"

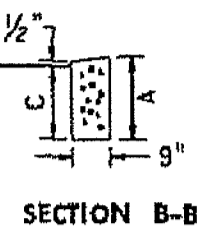

DEPRESSED CURB DETAIL

N.T.S.

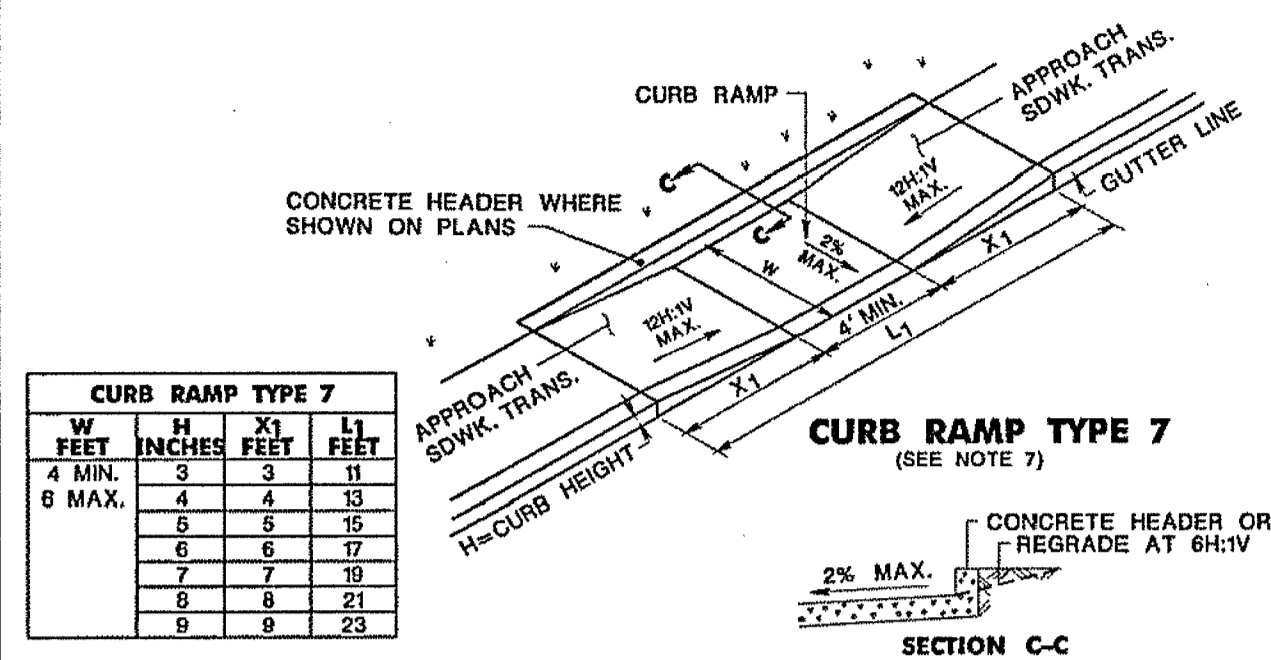

NJ DOT TYPE 7 HANDICAP RAMP DETAIL

N.T.S.

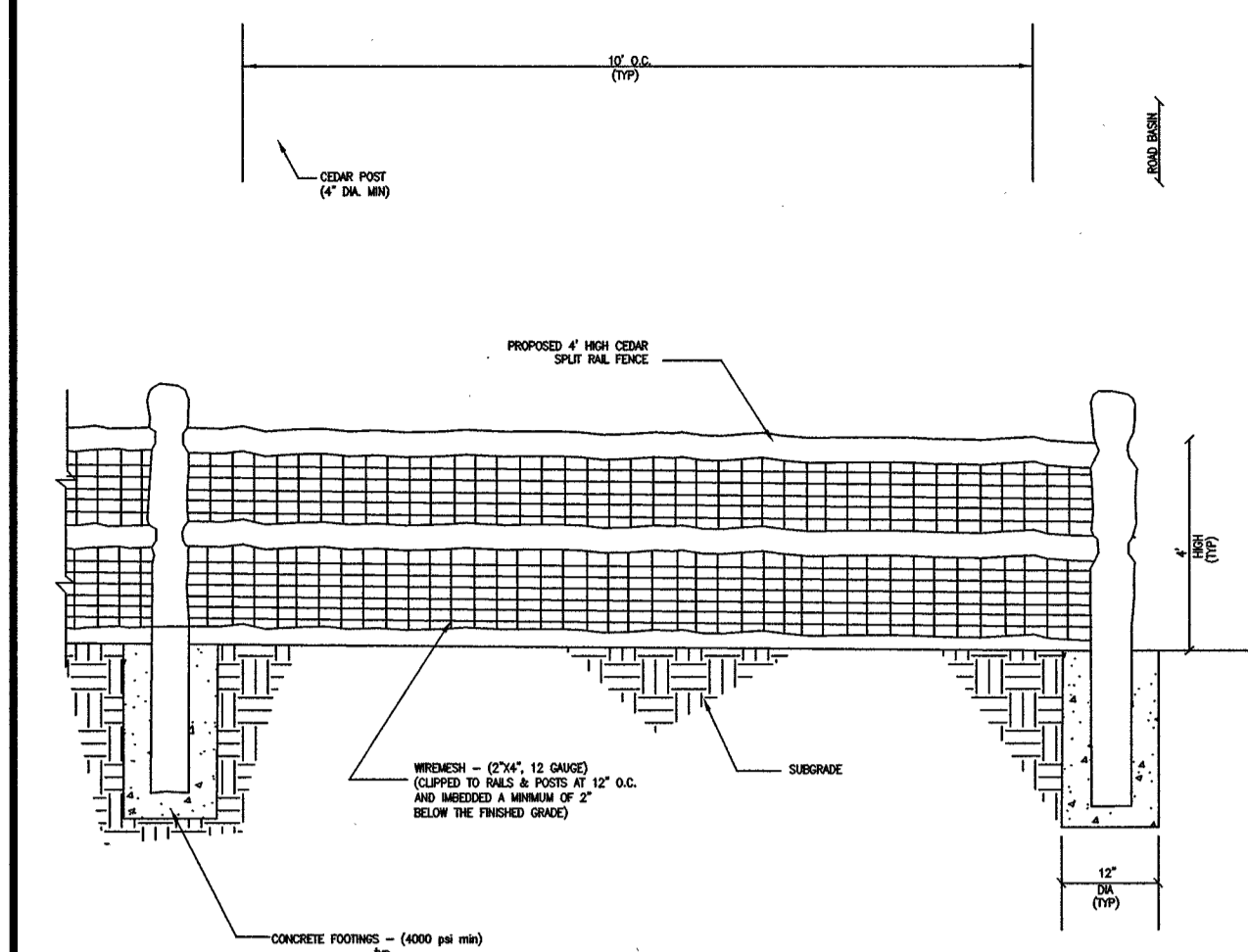

SPLIT RAIL BASIN FENCE DETAIL

N.T.S.

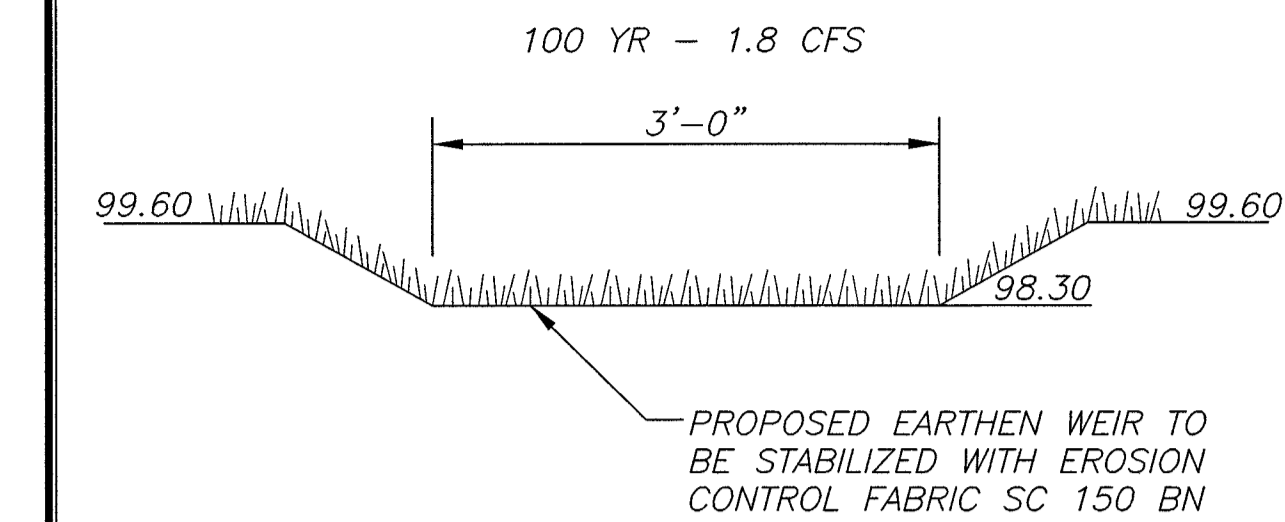

EMERGENCY WEIR DETAIL

N.T.S.

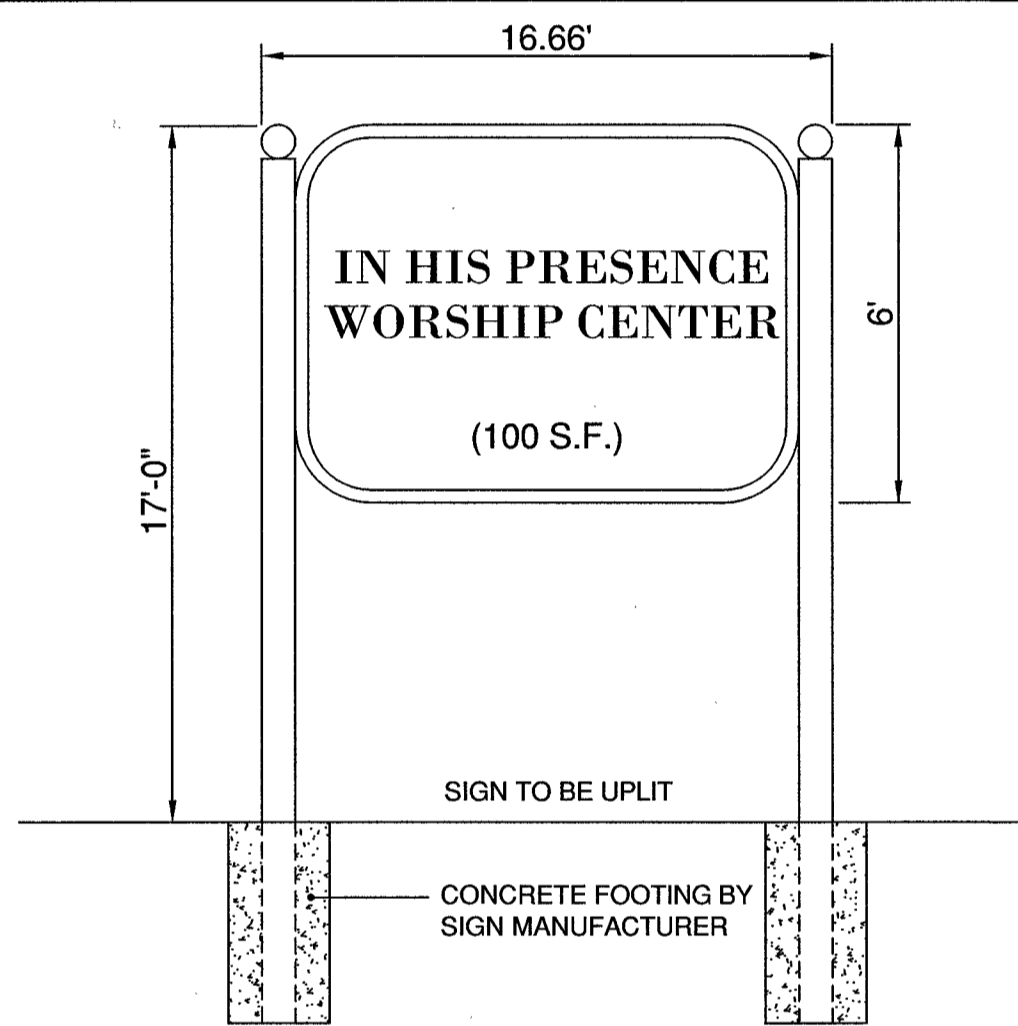

FREESTANDING SIGN DETAIL

N.T.S.

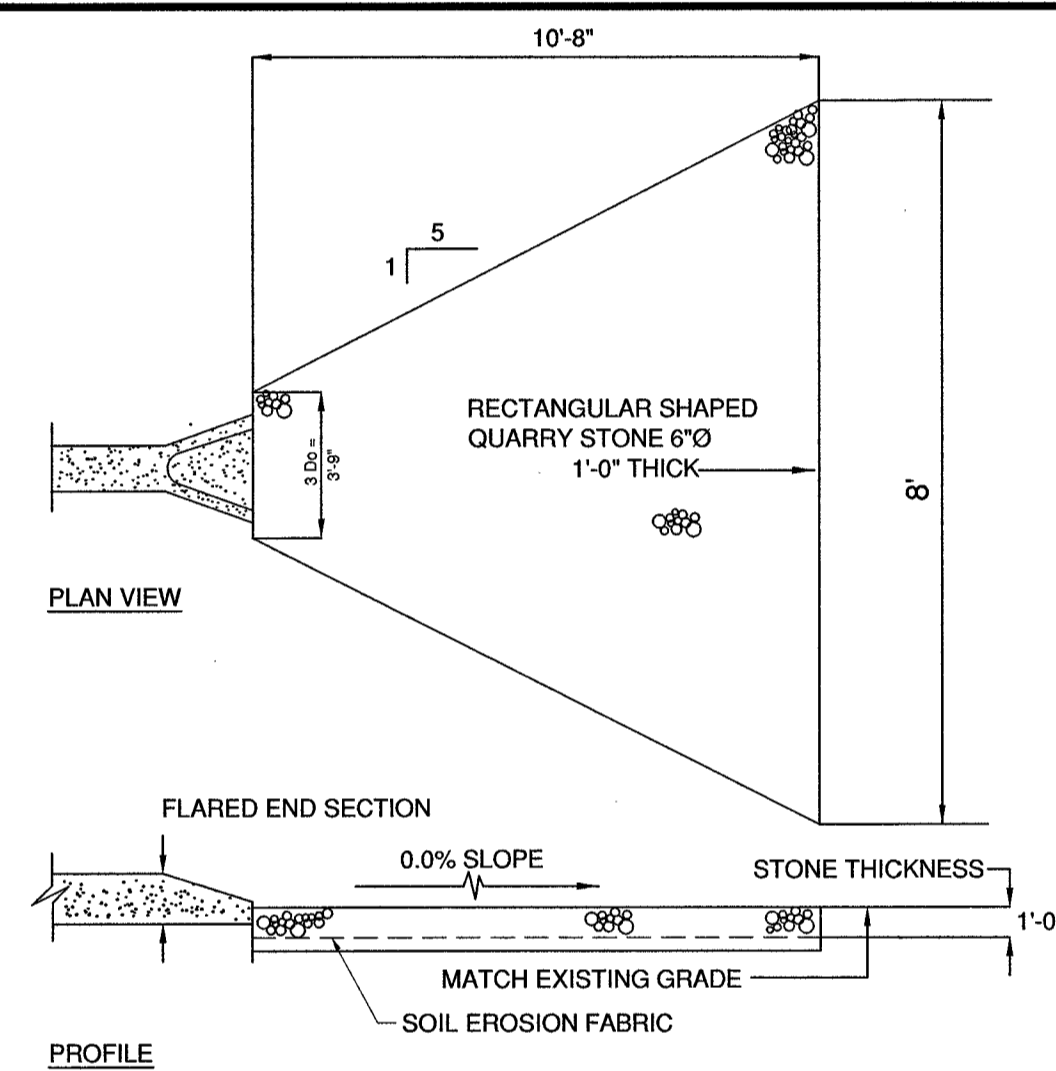

STONE APRON DETAIL #1

N.T.S.

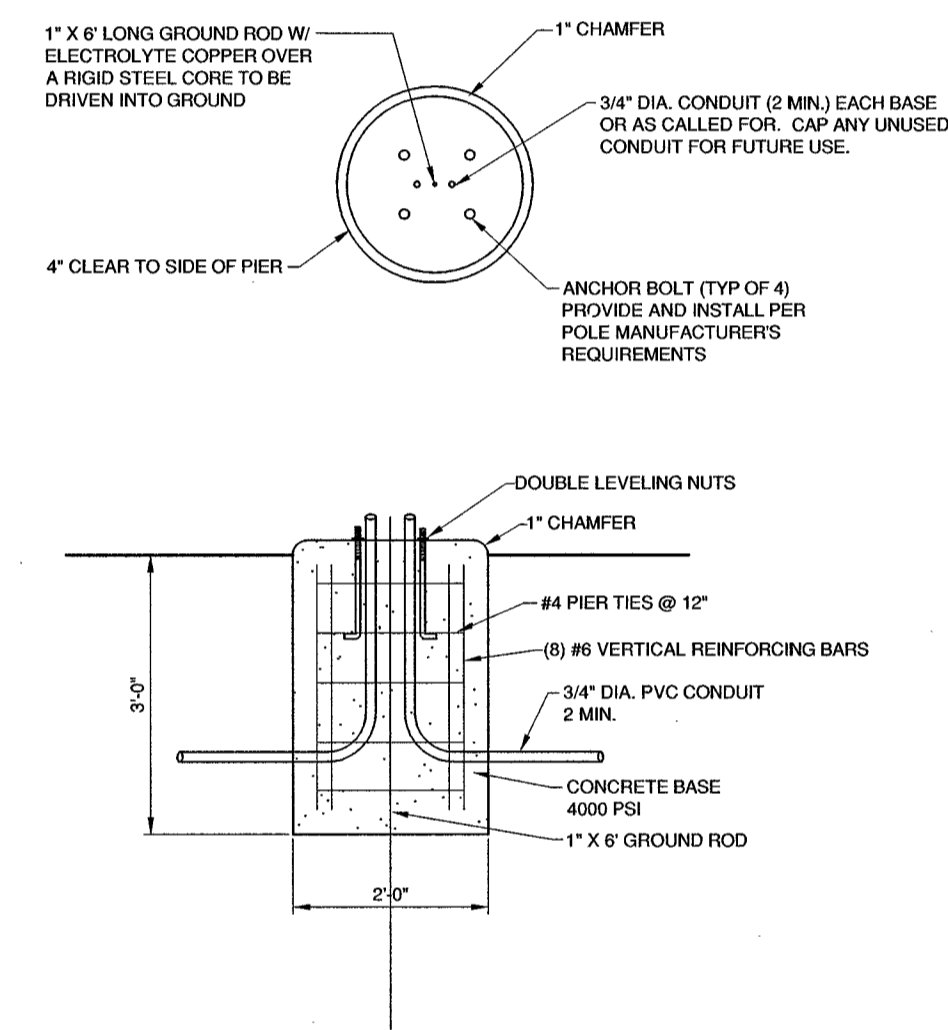

LIGHT POLE BASE DETAIL

N.T.S.

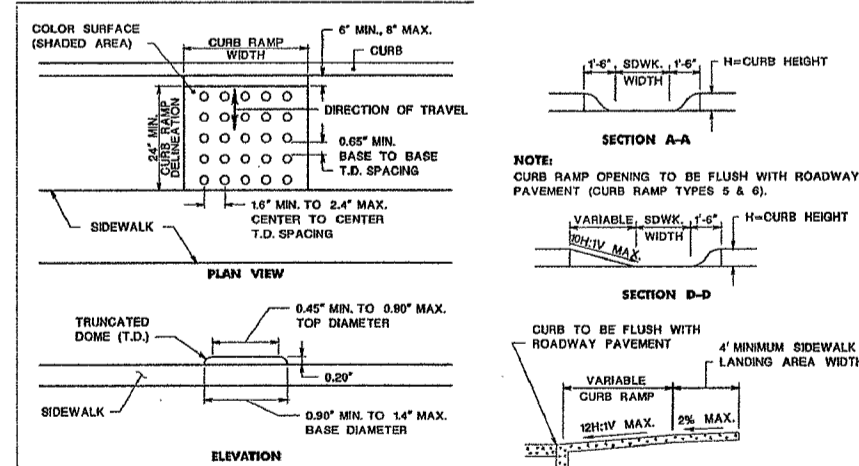

HANDICAP RAMP DETAIL NOTES

N.T.S.

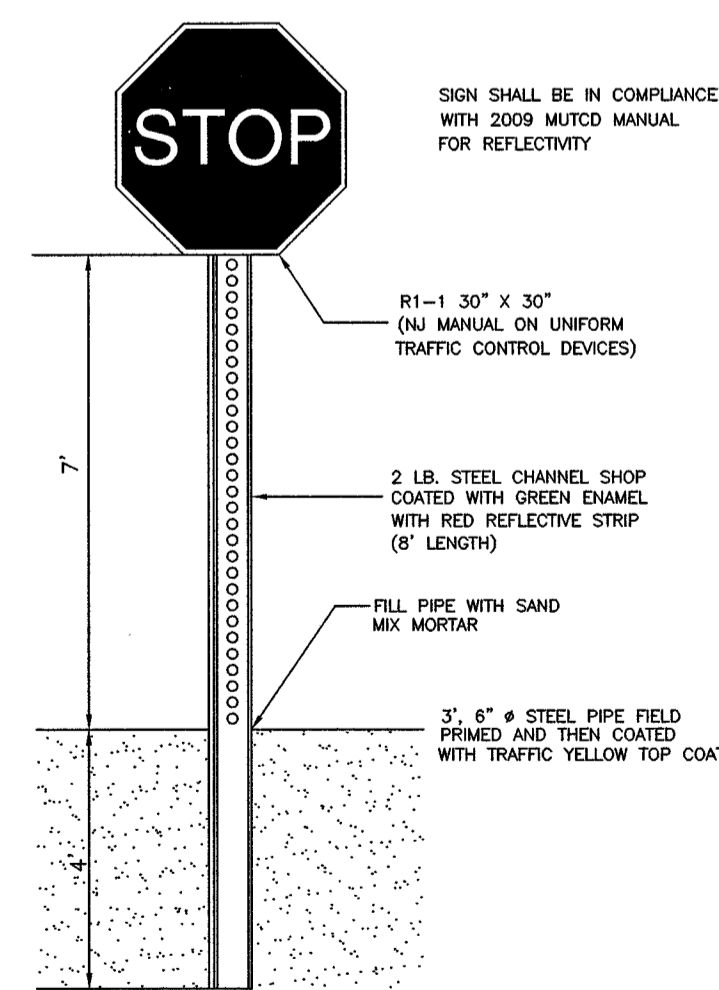

STOP SIGN DETAIL

N.T.S.

EDA Engineering Design Associates, P.A.
 Environmental Planners, Landscape Architects

CAMBRIDGE PROFESSIONAL OFFICES
 5 Cambridge Drive Ocean View New Jersey 08230
 (609) 390-0332 • Fax (609) 390-9204
 CERTIFICATE OF AUTHORIZATION: Z662767000

ENGINEERING DETAILS 3
 BLOCK 6701, LOT 3
 TOWNSHIP OF FRANKLIN
 GLOUCESTER COUNTY, NEW JERSEY

JOSEPH H. MAFFEI
 PROFESSIONAL ENGINEER
 N.J.P.E. LIC. #37984

Signature of Joseph H. Maffei

IF THIS PLAN OR DOCUMENT DOES NOT CONTAIN A RAISED SEAL IMPRESSION BEARING THE NAME AND REGISTRATION NUMBER OF THE ABOVE SIGNED PROFESSIONAL, IT MAY NOT BE AN AUTHORIZED COPY OF THE ORIGINAL DOCUMENT AND MAY HAVE BEEN ALTERED. REPRODUCTION OR FURTHER DISSEMINATION OF THE CONTENTS IN WHOLE OR IN PART REQUIRES PERMISSION IN WRITING FROM ENGINEERING DESIGN ASSOCIATES, P.A.

REV. PER ZONING BRD.	12-16-14	JLB
REV. PER PINELANDS	5-19-14	JLB
REVISION	DATE	BY

EDA

DATE: 3/14/14	DRAWN BY: JLB
SCALE: AS NOTED	CHECKED BY: JHM
PROJECT #: 6745	SHEET: 8 OF 9